

## FLEXDUR

Disc coupling

[www.reich-kupplungen.com](http://www.reich-kupplungen.com)



SIMPLY **POWERFUL.**



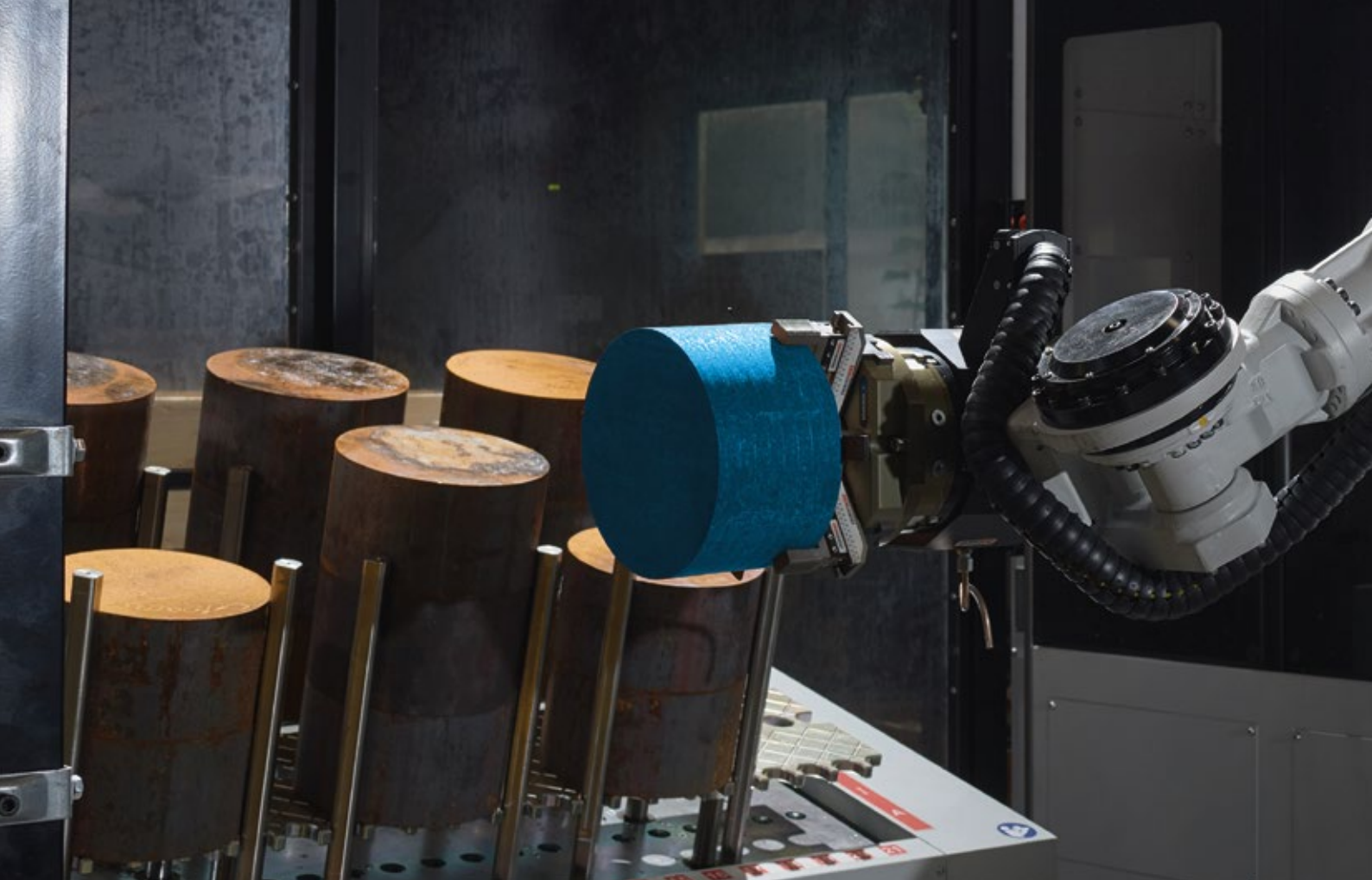

## D2C – Designed to Customer

The guiding principle of Designed to Customer is the recipe for success behind REICH. In addition to the catalogue products, we supply our customers with couplings developed to their specific requirements. The designs are mainly based on modular components to provide effective and efficient customer solutions. The special nature of our close cooperation with our partners ranges from; consulting, development, design, manufacture and integration to existing environments, to customer-specific production, logistics concepts and after-sales service - worldwide. This customer-oriented concept applies to both standard products and production in small batch sizes.

The company policy at REICH embraces, first and foremost, principles such as customer satisfaction, flexibility, quality, prompt delivery and adaptability to the requirements of our customers.

REICH supplies not only a coupling, but a solution:  
Designed to Customer – SIMPLY **POWERFUL**.



A large industrial robot arm, likely a Mazak model, is shown in a dark industrial setting. The arm is white and grey, with a prominent orange safety light at the end. The background shows the interior of a factory or workshop.

# FLEXDUR

## Contents

## Coupling Information

**04** General Technical Description

---

**05** Advantages and Uses

---

**06** Standard Types

---

**08** Special Types

---

**10** General Technical Data

---

**16** Selection of the Coupling Size

## Dimension Tables

**18** Type N + S

---

**20** Type CA + CB

---

**22** Type NO + SO

---

**24** Type NX + SX

---

**26** Type NZ + SZ

---

**28** Type F

---

**30** Type NY + SY

---

**32** Type NK + SK

---

**34** Type SP-CA + SP-CB

# FLEXDUR

## General Technical Description

### FLEXDUR

## Torsionally rigid, flexible coupling

The coupling uses bushed flexible disc packs of stainless spring steel as power transmitting elements. The special shape of the precision bushes results in a uniform tension distribution of the disc pack. The high grade fitting screws ensure backlash-free torque transmission.

**The FLEXDUR (short form: FD-C) has a modular design and can therefore be adapted to a wide variety of installation situations:**

FLEXDUR 1 (e.g. type N) can be used as a single joint coupling with a flexible disc pack to compensate for axial and angular displacement.

FLEXDUR 2 (e.g. type S) as a double-jointed coupling with two flexible disc packs compensates for axial, radial and angular displacement and is therefore flexible in all directions. Different mounting lengths are available as standard.

In addition to the standard FD-C version a design with strengthened discs, FD-CL, is available. Special designs e.g. for vertical mounting positions are possible on request.

For totally backlash free connection, designs with clamping hubs can be used.

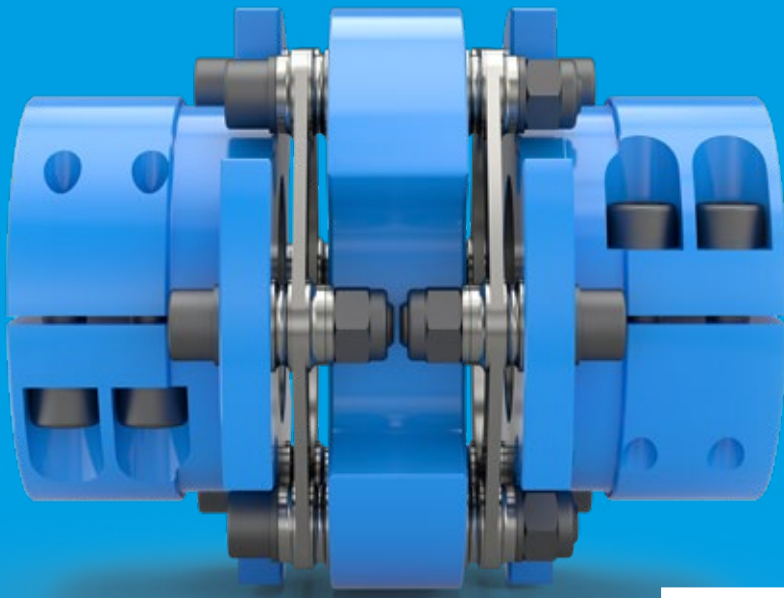

## FLEXDUR

Nominal torques from 18 Nm to 130 000 Nm

## FLEXDUR

### Advantages and Uses

#### Key features and benefits of the FLEXDUR coupling:

→ Torsionally rigid and backlash-free torque transmission	→ Long service life even with alternating loads with zero passage.
→ Compensation of axial, radial and angular shaft displacements	→ Ensures a high level of operational stability of your system with reduced loads, thereby increasing your productivity
→ Small restoring forces for shaft displacement by means of disc packs	→ Long service life, lower life cycle costs
→ No maintenance or lubrication required	→ Little effort during the period of use You have fewer down-times. Less maintenance for optimised operating costs
→ For use at ambient temperatures from -25 °C to +250 °C	→ Global use possible under the toughest conditions
→ Compact design, also suitable for high speeds	→ Large range of use, including for applications with little installation space
→ Almost unlimited lifetime and wear-free with proper shaft alignment	→ High cost-efficiency
→ Extended range of application due to Atex 	→ High level of safety, as it can be used in potentially explosive environments
→ Modular type	→ Optimum cost-benefit ratio Favourable investment costs, high cost-efficiency



# FLEXDUR

## Standard Types

Single joint FD-C 1



**FD-C N**

Standard



Double joint FD-C 2



**FD-C CA**

compact, short type



Double joint FD-C 2



**FD-C S DBSEmin**

Standard, short type



Double joint FD-C 2



**FD-C CB**

compact



Double joint FD-C 2



**FD-C S**

Standard



### FD-C NO

Flange version



Single joint FD-C 1

### FD-C SO DBSEmin

flange version, short type



Double joint FD-C 2

### FD-C SO

Flange version



Double joint FD-C 2

# FLEXDUR

## Special Types

Single joint FD-C 1



### FD-C NX

with internal locking device

Single joint FD-C 1



### FD-C NZ

clamping with shrink disc



Double joint FD-C 2



### FD-C SX DBSEmin

with internal locking device, short type

Double joint FD-C 2



### FD-C SZ DBSEmin

clamping with shrink disc, short type



Double joint FD-C 2



### FD-C SX

with internal locking device

Double joint FD-C 2



### FD-C SZ

clamping with shrink disc



Double joint FD-C 2



### FD-C F

API 610+API 671





### FD-C NY

with clamping hub,  
split



Single joint FD-C 1

### FD-C NK

with clamping hub,  
slotted



Single joint FD-C 1

### FD-C SY DBSEmin

with clamping hub,  
split, short type



Double joint FD-C 2

### FD-C SK DBSEmin

with clamping hub,  
slotted, short type



Double joint FD-C 2

### FD-C SY

with clamping hub,  
split



Double joint FD-C 2

### FD-C SK

with clamping hub,  
slotted



Double joint FD-C 2

### FD-C SP-CA

compact, short type  
split spacer



Double joint FD-C 2

### FD-C SP-CB

compact, split spacer



Double joint FD-C 2

# FLEXDUR FD-C

## General Technical Data

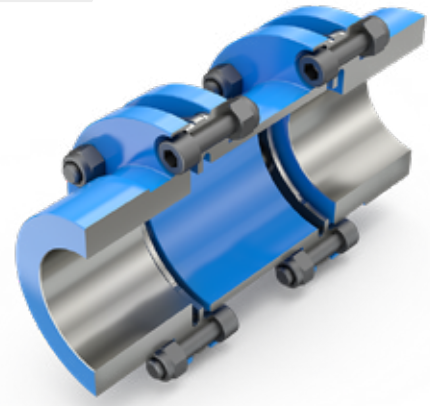

### Standard Design

Coupling size				FD-C 1 Single joint coupling					FD-C 2 Double joint coupling						
	Nominal torque	Maximum torque	Maximum speed	Permissible displacement			Moment of inertia	Dynamic torsional stiffness	Spacer DBSE <sup>1)</sup> [mm]	Permissible displacement			Moment of inertia	Dynamic torsional stiffness	
	$T_{KN}$ [Nm]	$T_{Kmax}$ [Nm]	$n^{2)}$ [min <sup>-1</sup> ]	$\Delta K_a$ [± mm]	$\Delta K_r$ [mm]	$\Delta K_w$ [°]	J [kgm <sup>2</sup> ]	$C_T$ [kNm/rad]		$\Delta K_a$ [± mm]	$\Delta K_r$ [mm]	$\Delta K_w$ [°]	J [kgm <sup>2</sup> ]	$C_T$ [kNm/rad]	
FD-C 40	18	31.5	16700	0.4	0	1.0	0.00002	19	16.0	0.8	0.2	2	0.00004	9	
									26.0						0.3
FD-C 53	90	157	16200	0.4	0	1.0	0.00011	90	30.0	0.8	0.3	2	0.00016	44	
									43.0						0.4
FD-C 72	170	295	12200	0.5	0	1.0	0.00049	173	31.2	1.1	0.3	2	0.00071	84	
									60.0						0.8
									100.0						1.5
									140.0						2.2
FD-C 89	320	560	9900	0.6	0	1.0	0.0016	281	37.6	1.2	0.4	2	0.0022	136	
									70.0						1
									80.0						1.1
									100.0						1.5
FD-C 118	750	1310	7500	0.8	0	1.0	0.0059	637	140.0	1.6	0.5	2	0.0080	309	
									100.0						1.4
									140.0						2.1
									180.0						2.8
FD-C 142	1350	2360	6200	1.0	0	1.0	0.014	1173	55.0	2.1	0.7	2	0.018	569	
									100.0						1.5
									140.0						2.1
									180.0						2.8
FD-C 168	2400	4200	5250	1.2	0	1.0	0.035	2000	62.6	2.5	0.9	2	0.039	952	
									100.0						1.4
									140.0						2.1
									180.0						2.8
FD-C 200	4000	7000	4400	1.4	0	1.0	0.084	2992	140.0	2.8	2	2	0.12	1306	
									180.0						2.7
FD-C 238	6500	11375	3650	1.7	0	1.0	0.23	5269	140.0	3.4	2	2	0.34	2467	
									180.0						2.6
									250.0						3.8
FD-C 295	21000	36750	2950	1.1	0	0.5	0.70	21848	200.0	2.2	1.4	1	1.07	8995	
									250.0						1.8
FD-C 345	36000	63000	2500	1.3	0	0.5	1.75	37204	224.0	2.6	1.6	1	2.62	14975	
									250.0						1.8
									300.0						2.2
FD-C 420	74000	129500	2050	1.6	0	0.5	3.26	46192	280.0	3.2	2.5	1	5.35	18116	
FD-C 510	130000	227500	1700	2.0	0	0.5	8.65	87706	350.0	4	3	1	14.43	36134	

<sup>1)</sup> DBSE available up to 3 000 mm upon request    <sup>2)</sup> Higher speeds only following consultation

# FLEXDUR FD-CL

## General Technical Data

### Standard Design

Coupling size				FD-CL 1 Single joint coupling					FD-CL 2 Double joint coupling								
	Nominal torque	Maximum torque	Maximum speed	Permissible displacement			Moment of inertia	Dynamic torsional stiffness	Spacer	Permissible displacement			Moment of inertia	Dynamic torsional stiffness			
	$T_{KN}$ [Nm]	$T_{Kmax}$ [Nm]	$n^{2)}$ [min <sup>-1</sup> ]	$\Delta K_a$ [± mm]	$\Delta K_r$ [mm]	$\Delta K_w$ [°]	J [kgm <sup>2</sup> ]	$C_T$ [kNm/rad]	DBSE <sup>1)</sup> [mm]	$\Delta K_a$ [± mm]	$\Delta K_r$ [mm]	$\Delta K_w$ [°]	J [kgm <sup>2</sup> ]	$C_T$ [kNm/rad]			
FD-CL 72	230	402.5	12200	0.4	0	0.7	0.00049	184	31.4	0.8	0.2	1.4	0.00070	89			
									60.2						0.6	0.00076	75
									100.2						1.1	0.00081	62
									140.2						1.5	0.00087	53
FD-CL 89	420	735.0	9900	0.5	0	0.7	0.016	312	38.0	1.0	0.3	1.4	0.00219	151			
									70.4						0.7	0.0025	139
									80.4						0.8	0.0026	134
									100.4						1.1	0.0027	127
									140.4						1.6	0.0028	114
FD-CL 118	1050	1837.5	7500	0.6	0	0.7	0.0059	743	47.1	1.2	0.4	1.4	0.00812	360			
									100.8						1.1	0.0091	308
									140.8						1.5	0.0095	277
									180.8						2.1	0.0099	251
FD-CL 142	1750	3062.5	6200	0.7	0	0.7	0.014	1251	55.4	1.4	0.5	1.4	0.01840	607			
									100.4						1.0	0.021	543
									140.4						1.5	0.022	494
									180.4						2.0	0.023	454
FD-CL 168	3000	5250.0	5250	0.8	0	0.7	0.035	2082	62.6	1.6	0.6	1.4	0.039	990			
									100.0						1.0	0.052	948
									140.0						1.5	0.054	884
									180.0						2.0	0.056	829
FD-CL 200	5200	9100.0	4400	1.0	0	0.7	0.084	3142	140.4	2.0	1.5	1.4	0.12	1362			
									180.4						2.0	0.13	1279
FD-CL 238	11000	19250.0	3650	1.2	0	0.7	0.23	6586	142.4	2.4	1.4	1.4	0.34	3035			
									182.4						1.9	0.35	2898
									252.4						2.7	0.36	2686
FD-CL 295	26000	45500.0	2950	0.8	0	0.4	0.70	22285	200.4	1.6	1.2	0.8	1.07	9142			
									250.4						1.5	1.10	8389
FD-CL 345	44000	77000.0	2500	0.9	0	0.4	1.75	37868	224.4	1.8	1.3	0.8	2.62	15190			
									250.4						1.5	2.64	14497
									300.4						1.8	2.68	13328

**i** 1) DBSE available up to 3 000 mm upon request    2) Higher speeds only following consultation

# FLEXDUR FD-C

## General Technical Data



### Special types FD-C F

FD-C 2  
Double joint coupling

Coupling size	Nominal torque	Maximum torque	Maximum speed	Spacer		Permissible displacement				Moment of inertia		Dynamic torsional stiffness	
	$T_{KN}$	$T_{Kmax}$	n	DBSE <sub>min</sub>	DBSE	$\Delta K_a$	$\Delta K_r$ for DBSE <sub>min</sub>	$\Delta K_r$	$\Delta K_w$	J for DBSE <sub>min</sub>	J	$C_T$ for DBSE <sub>min</sub>	$C_T$
	[Nm]	[Nm]	[min <sup>-1</sup> ]	[mm]	[mm]	[± mm]	[mm]	[mm]	[°]	[kgm <sup>2</sup> ]	[kgm <sup>2</sup> ]	[kNm/rad]	[kNm/rad]
FD-C 89	320	560	15800	50.0	62.0	1.2	0.7	0.93	2	0.0054	0.0055	134.0	129.6
					102.0			1.63			0.0057		116.8
FD-C 118	750	1310	12300	61.0	96.0	1.6	0.9	1.49	2	0.0184	0.0188	300.2	273.1
					136.0			2.19			0.0192		247.5
FD-C 142	1350	2360	10000	63.0	91.0	2.1	0.9	1.38	2	0.0485	0.0491	561.2	524.0
					131.0			2.08			0.0501		478.7
FD-C 168	2400	4200	8400	74.0	119.0	2.5	1.0	1.85	2	0.1114	0.1127	909.4	818.7
					189.0			3.07			0.1149		691.5
FD-C 200	4000	7000	7400	90.0	110.0	2.8	1.3	1.66	2	0.2649	0.2661	1383.4	1321.3
					180.0			2.88			0.2701		1141.8
FD-C 238	6500	11375	6000	105.4	167.4	3.4	1.5	2.56	2	0.6501	0.6618	2525.1	2335.9
					217.4			3.43			0.6713		2202.8
FD-C 295	21000	36750	4900	138.0	153.0	2.2	0.9	1.09	1	1.7477	1.7522	9573.5	9149.4
					203.0			1.53			1.7674		7972.0
FD-C 345	36000	63000	4200	155.0	177.0	2.6	1.0	1.26	1	3.9224	3.9400	17098.0	16344.8
					227.0			1.70			3.9800		14857.4

# FLEXDUR FD-CL

## General Technical Data

### Special types FD-CL F

#### FD-CL 2 Double joint coupling

Coupling size	Nominal torque	Maximum torque	Maximum speed	Spacer		Permissible displacement				Moment of inertia		Dynamic torsional stiffness	
	$T_{KN}$	$T_{Kmax}$	n	DBSE <sub>min</sub>	DBSE	$\Delta K_a$	$\Delta K_r$ for DBSE <sub>min</sub>	$\Delta K_r$	$\Delta K_w$	J for DBSE <sub>min</sub>	J	$C_T$ for DBSE <sub>min</sub>	$C_T$
	[Nm]	[Nm]	[min <sup>-1</sup> ]	[mm]	[mm]	[± mm]	[mm]	[mm]	[°]	[kgm <sup>2</sup> ]	[kgm <sup>2</sup> ]	[kNm/rad]	[kNm/rad]
FD-CL 89	420	735.0	15800	50.4	62.4	1.0	0.5	0.65	1.4	0.0054	0.0055	148.0	142.7
					102.4			1.14			0.0057		127.3
FD-CL 118	1050	1837.5	12300	61.8	96.8	1.2	0.6	1.05	1.4	0.0184	0.0188	346.9	311.1
					136.8			1.54			0.0192		278.3
FD-CL 142	1750	3062.5	10000	63.4	91.4	1.4	0.6	0.97	1.4	0.0485	0.0491	596.8	554.9
					131.4			1.46			0.0501		504.4
FD-CL 168	3000	5250.0	8400	74.0	119.0	1.6	0.7	1.29	1.4	0.1114	0.1123	963.7	846.0
					189.0			2.15			0.1149		710.8
FD-CL 200	5200	9100.0	7400	90.4	110.4	2.0	0.9	1.16	1.4	0.2649	0.2661	1447.3	1379.4
					180.4			2.02			0.2701		1184.9
FD-CL 238	11000	19250.0	6000	107.8	169.8	2.4	1.0	1.81	1.4	0.6501	0.6618	3123.8	2839.3
					219.4			2.42			0.6713		2645.0
FD-CL 295	26000	45500.0	4900	138.4	153.4	1.6	0.8	0.87	0.8	1.7477	1.7522	9740.9	9302.1
					203.4			1.22			1.7674		8087.8
FD-CL 345	44000	77000.0	4200	155.4	177.4	1.8	0.9	1.01	0.8	3.9224	3.9400	17378.1	16600.6
					227.4			1.36			3.9800		15068.4



# FLEXDUR FD-C

## General Technical Data



### Special types FD-C SP

FD-C 2  
Double joint coupling

Coupling size	Nominal torque	Maximum torque	Maximum speed	Spacer	Permissible displacement			Moment of inertia		Dynamic torsional stiffness
	$T_{KN}$	$T_{Kmax}$	$n$	DBSE	$\Delta K_a$	$\Delta K_r$	$\Delta K_w$	J CA	J CB	$C_T$
	[Nm]	[Nm]	[min <sup>-1</sup> ]	[mm]	[± mm]	[mm]	[°]	[kgm <sup>2</sup> ]	[kgm <sup>2</sup> ]	[kNm/rad]
FD-C 89	320	560	9900	80.0	1.2	1.2	2	0.0023	0.0024	127.1
FD-C 118	750	1310	7500	79.0	1.6	1.2	2	0.0196	0.0208	298.6
FD-C 142	1350	2360	6200	93.0	2.1	1.5	2	0.1053	0.1110	546.3
FD-C 168	2400	4200	5250	112.0	2.5	1.7	2	0.8306	0.9173	942.7
FD-C 200	4000	7000	4400	124.0	2.8	1.9	2	0.2649	0.2649	1404.8
FD-C 238	6500	11375	3650	144.0	3.4	2.2	2	0.6501	0.6501	2527.4
FD-C 295	21000	36750	2950	199.0	2.2	1.5	1	1.7477	1.7477	9843.9
FD-C 345	36000	63000	2500	223.0	2.6	1.7	1	3.9224	3.9224	16947.3

# FLEXDUR FD-CL

## General Technical Data

### Special types FD-CL SP

#### FD-CL 2 Double joint coupling

Coupling size	Nominal torque	Maximum torque	Maximum speed	Spacer	Permissible displacement			Moment of inertia		Dynamic torsional stiffness
	$T_{KN}$	$T_{Kmax}$	$n$	DBSE	$\Delta K_a$	$\Delta K_r$	$\Delta K_w$	J CA	J CB	$C_T$
	[Nm]	[Nm]	[min <sup>-1</sup> ]	[mm]	[± mm]	[mm]	[°]	[kgm <sup>2</sup> ]	[kgm <sup>2</sup> ]	[kNm/rad]
FD-CL 89	420	735.0	9900	80.4	1.0	0.9	1.4	0.0023	0.0024	139.6
FD-CL 118	1050	1837.5	7500	79.8	1.2	0.9	1.4	0.0076	0.0081	344.8
FD-CL 142	1750	3062.5	6200	93.4	1.4	1.0	1.4	0.0196	0.0208	580.0
FD-CL 168	3000	5250.0	5250	112.0	1.6	1.2	1.4	0.0473	0.0502	979.1
FD-CL 200	5200	9100.0	4400	124.4	2.0	1.3	1.4	0.1053	0.1110	1470.8
FD-CL 238	11000	19250.0	3650	146.4	2.4	1.6	1.4	0.2596	0.2936	3127.3
FD-CL 295	26000	45500.0	2950	199.4	1.6	1.2	0.8	0.8306	0.9173	10021.0
FD-CL 345	44000	77000.0	2500	223.4	1.8	1.3	0.8	1.8281	2.1153	17222.4

# FLEXDUR

## Selection of the Coupling Size

First the service factor ( $S_f$ ) is determined: it is based on the displacement factor ( $S_1$ ), the load factor ( $S_2$ ) and the temperature factor ( $S_3$ ):

$S_f = S_1 \cdot S_2 \cdot S_3$  (see following sections).

The product of service factor ( $S_f$ ) and transmitted torque  $T$  must not exceed the nominal torque  $T_{KN}$  (acc. table "General Technical Data").

$T_{KN} > T \cdot S_f$

### Displacement factor $S_1$

The values for displacement, given in the table 'General technical data', are maximum values which may not occur simultaneously. An existing axial displacement  $\Delta K_a$  as shown in fig.1 reduces the permissible values for radial displacement  $\Delta K_r$  and angular displacement  $\Delta K_w$ . The total angular displacement  $\Sigma \Delta K$  [°] is calculated from the formula:

$$\Sigma \Delta K [^\circ] = \frac{\Delta K_w}{2} + \arctan \frac{\Delta K_r}{(DBSE - S)}$$

(Values for DBSE and S per table "Standard size" on page 10)

The displacement factor ( $S_1$ ) is a function of  $\Sigma \Delta K$  [°] acc. to fig. 2.

### Load factor $S_2$

for electric or hydraulic motors, gas or steam turbines.

The load factor must be increased:

Driven machine	$S_2$
Paper machines and textile machines	2.00
Woodworking machines, gear pumps, conveyors	1.50
Machine tools: main drives	1.75
Machine tools: auxiliary drives	1.10
Elevators and cranes	2.00
Mills, reciprocating pumps	2.50
Centrifugal pumps: small inertias and thin fluid materials	1.10
Centrifugal pumps: large inertias or semi-fluid materials	1.75
Presses	3.00
Blowers with low inertias	1.10
Blowers with high inertias	2.00

- $S_2+1$ : for applications with 4- or 5-cylinder combustion engines
- $S_2+0.5$ : for applications with 6-cylinder combustion engines, hydraulic turbines or at starting torque  $\geq 2$ .
- Applications with high recurring peak loads:
  - non-reversing duty:  $T_{KN} > \text{max peak load}$
  - reversing duty:  $T_{KN} > 1.5 \times \text{max. peak load}$

### Temperature factor $S_3$

FLEXDUR can be used up to 80 °C as a standard. Higher temperatures must be specified in the order due to the use of self-locking nuts with plastic ring. For temperatures above 160 °C, the factor  $S_3$  must be selected acc. to fig. 3.

## General Technical Information

The technical data applies only to the complete coupling or the corresponding coupling elements. It is the customer/user's responsibility to ensure that there are no inadmissible loads acting on any of the components. In particular, existing connections, e.g. bolted connections, must be checked with regard to the torques to be transmitted. If necessary, further measures, such as additional reinforcement with pins, may be necessary. It is the customer/user's responsibility to make sure the dimensioning of the shaft and keyed or other connection, e.g. shrinking or clamping connection, is correct. All components that can rust are protected against

corrosion as standard. REICH have an extensive range of couplings and coupling systems to cover nearly every drive configuration. Customised solutions can be developed and manufactured even in small batches or as prototypes. In addition calculation programs are available for all necessary dimensioning.

## Diagrams

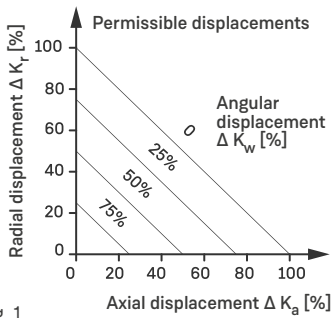

Fig. 1

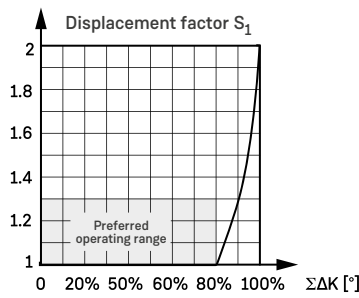

Fig. 2

**i** Note: Displacements which have occurred during operation (e.g. thermal factor) must be taken into account. For larger displacements please contact us.

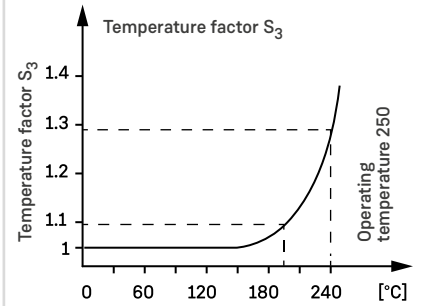

Fig. 3

**i** Note: Application temperatures above 80° must be specified in the order.

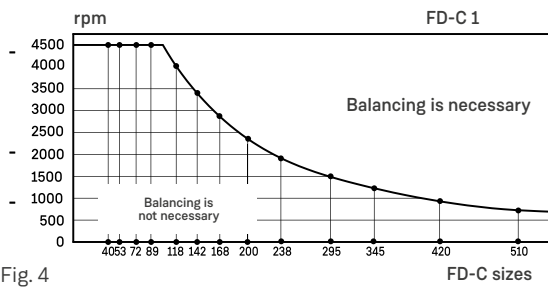

Fig. 4

**i** The balancing grade for the standard elements is G 6.3 according to DIN ISO 21940. Balancing is recommended at operating speeds above the curves shown in Figures 4 and 5.

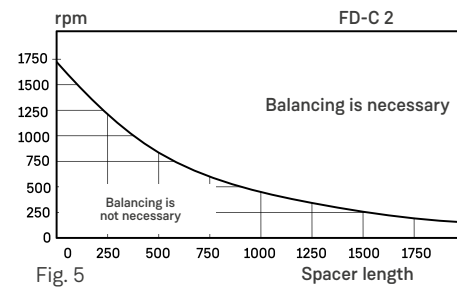

Fig. 5

## Ordering example

Element version	Size	Number of screws	Version	Mounting situation	Hub type	Type of bore
FD-C = Standard			N = Single joint coupling standard	Distance between shaft ends (DBSE) (Type N - no declaration)		with key connection acc. to DIN 6885/1 => Ø D <sub>1</sub> or Ø D <sub>9</sub>
FD-CL = Strengthened			S = Double joint coupling standard		O = Flange coupling for Drop-Out version	with K => Ø D <sub>11</sub> with Z => Ø D <sub>7</sub> + Ø D <sub>6</sub>
			CA = Compact, two hubs mounted to the inside		K = Clamping hub, slotted	with Y => type of clamping element + Ø D <sub>6</sub>
			CB = Compact, one hub mounted to the inside		Z = Outside clamping set	with X => type of clamping element + Ø D <sub>3</sub>
			F = Double joint coupling, compliant with API 610, API 671 and ATEX		Y = Clamping hub, split	
			SP-CA = Split spacer, two hubs mounted to the inside		X = Internal locking device	
			SP-CB = Split spacer, one hub mounted to the inside		V <sub>1</sub> = small clamping bush design	
					V <sub>2</sub> = large clamping bush design	
FD-C	142 - 6	6	S	180	X	2820.50/2820.55

Designation: FD-C 142 - 6 S 180 X 2820.50 - X 2820.55

# FLEXDUR

## Type N + S

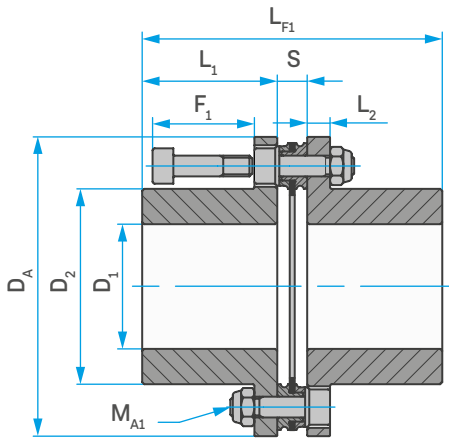

FD-C N: Standard

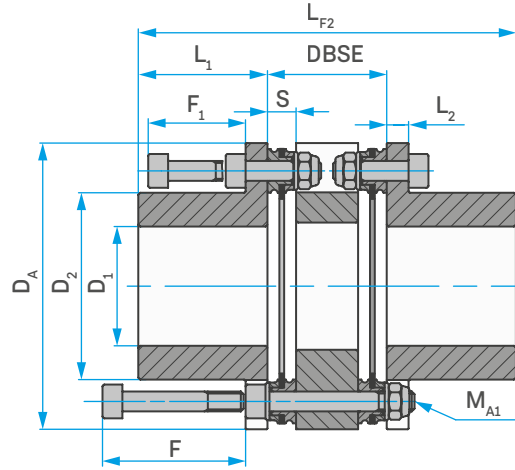

FD-C S DBSE<sub>min</sub>: Standard, short type



### Coupling details

Coupling size	L <sub>1</sub> [mm]	D <sub>A</sub> [mm]	D <sub>1min</sub> pre-drilled [mm]	D <sub>1max</sub> [mm]	D <sub>2</sub> [mm]	F [mm]	F <sub>1</sub> [mm]	L <sub>2</sub> [mm]
40	17.0	40.0	6	18	26.0	25	15	4
53	24.5	53.0	6	22	32.5	43	24	5
72	39.5	70.5	10	32	47.0	43	24	5
89	45.0	88.0	14	42	62.5	53	32	8
118	55.0	116.5	15	55	82.0	67	40	10
142	60.0	140.5	19	65	98.0	82	47	11
168	75.0	166.5	25	80	118.0	94	55	12
200	90.0	198.5	30	95	141.0	-	64	14
238	125.0	238.0	39	115	169.0	-	81	16
295	160.0	295.0	59	140	205.0	-	112	22
345	200.0	345.0	79	175	254.0	-	133	26
420	210.0	420.0	90	180	262.0	-	137	32
510	240.0	510.0	100	215	316.0	-	172	38



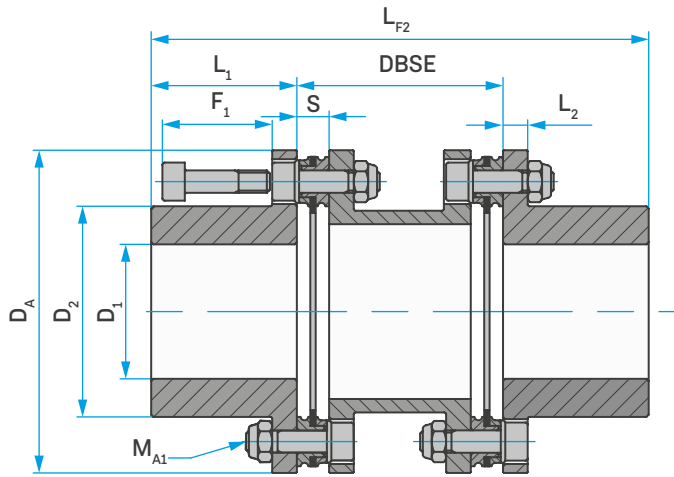

FD-C S: Standard

**Mounting instruction:**

Standard type, pilot bore or finish bore with keyway.  
Key connection not suitable for backlash-free torque transmission. Disc pack radial dismounting without hub displacement.

Coupling size	FD-C						FD-CL					
	$M_{A1}$		S	DBSE <sup>1)</sup>	$L_{F1}$	$L_{F2}$	$M_{A1}$		S	DBSE <sup>1)</sup>	$L_{F1}$	$L_{F2}$
	[-]	[Nm]	[mm]	[mm]	[mm]	[mm]	[-]	[Nm]	[mm]	[mm]	[mm]	[mm]
40	M3	1.5	2.9	16.0	36.9	50.0	-	-	-	-	-	-
				26.0		60.0						
53	M5	7.0	6.9	30.0	55.9	79.0	-	-	-	-	-	-
				43.0		92.0						
72	M5	8.0	7.5	31.2	86.5	110.2	M5	9.0	7.6	31.4	86.6	110.4
				60.0		139.0				60.2		139.2
				100.0		179.0				100.2		179.2
				140.0		219.0				140.2		219.2
				37.6		127.6				38.0		128.0
89	M6	14.0	8.8	70.0	98.8	160.0	M6	15.0	9.0	70.4	99.0	160.4
				80.0		170.0				80.4		170.4
				100.0		190.0				100.4		190.4
				140.0		230.0				140.4		230.4
				37.6		127.6				38.0		128.0
118	M8	31.0	10.4	46.3	120.4	156.3	M8	35.0	10.8	47.1	120.8	157.1
				100.0		210.0				100.8		210.8
				140.0		250.0				140.8		250.8
				180.0		290.0				180.8		290.8
				55.0		175.0				55.4		175.4
142	M10	62.0	12.0	100.0	132.0	220.0	M10	73.0	12.2	100.4	132.2	220.4
				140.0		260.0				140.4		260.4
				180.0		300.0				180.4		300.4
				62.6		212.6				62.6		212.6
168	M12	110.0	13.0	100.0	163.0	250.0	M12	130.0	13.0	100.0	163.0	250.0
				140.0		290.0				140.0		290.0
				180.0		330.0				180.0		330.0
				62.6		212.6				62.6		212.6
200	M14	180.0	15.0	140.0	195.0	320.0	M14	210.0	15.2	140.4	195.2	320.4
				180.0		360.0				180.4		360.4
238	M16	280.0	20.8	140.0	270.8	390.0	M16	320.0	22.0	142.4	272.0	392.4
				180.0		430.0				182.4		432.4
				250.0		500.0				252.4		502.4
295	M20	540.0	28.0	200.0	348.0	520.0	M20	620.0	28.2	200.4	348.2	520.4
				250.0		570.0				250.4		570.4
345	M24	950.0	32.2	224.0	432.2	624.0	M24	1000.0	32.4	224.4	432.4	624.4
				250.0		650.0				250.4		650.4
				300.0		700.0				300.4		700.4
420	M10	60.0	34.0	280.0	454.0	700.0	-	-	-	-	-	-
510	M12	105.0	46.8	350.0	526.8	830.0	-	-	-	-	-	-

<sup>1)</sup> DBSE available up to 3 000 mm upon request

# FLEXDUR

## Type CA + CB

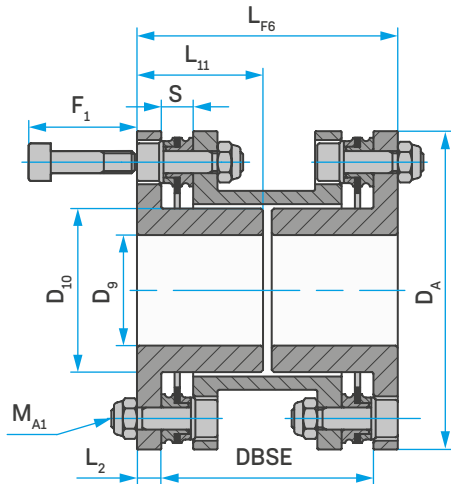

FD-C CA: compact, short type

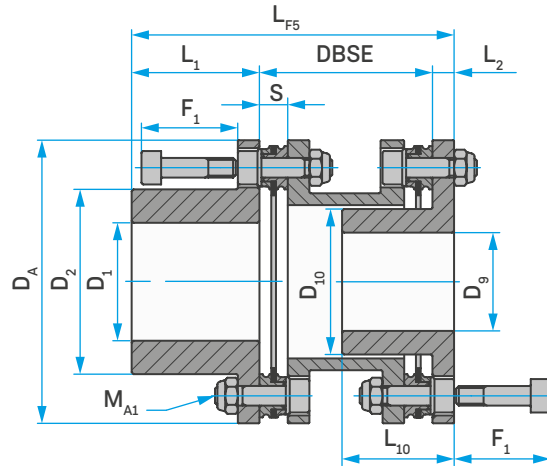

FD-C CB: compact



### Coupling details

Coupling size	L <sub>1</sub>	L <sub>3</sub>	L <sub>4</sub>	D <sub>A</sub>	D <sub>1min</sub> pre-drilled	D <sub>3min</sub> pre-drilled	D <sub>1max</sub>	D <sub>3max</sub>	D <sub>2</sub>	D <sub>4</sub>	F <sub>1</sub>	L <sub>2</sub>
	[mm]	[mm]	[mm]	[mm]	[mm]	[mm]	[mm]	[mm]	[mm]	[mm]	[mm]	[mm]
53	24.5	24.5	24.5	53.0	6	6	22	17	32.5	24.5	24	5
72	39.5	39.5	34.5	70.5	10	10	32	25	47.0	37.0	24	5
		39.5	39.5									
		39.5	39.5									
89	45.0	45.0	40.0	88.0	14	14	42	32	62.5	48.0	32	8
		45.0	45.0									
		45.0	45.0									
		45.0	45.0									
118	55.0	55.0	55.0	116.5	15	15	55	44	82.0	64.0	40	10
		55.0	55.0									
		55.0	55.0									
142	60.0	60.0	58.0	140.5	19	19	65	50	98.0	77.0	47	11
		60.0	60.0									
		60.0	60.0									
168	75.0	75.0	60.0	166.5	25	25	80	60	118.0	90.5	55	12
		75.0	75.0									
		75.0	75.0									
200	90.0	90.0	81.0	198.5	30	30	95	75	141.0	114.0	64	14
		90.0	90.0									
		90.0	90.0									
238	125.0	125.0	-	238.0	39	39	115	90	169.0	135.0	81	16
		125.0	104.0									
		125.0	125.0									
295	160.0	160.0	-	295.0	59	59	140	115	205.0	170.0	112	22
		160.0	140.0									
		160.0	140.0									
345	200.0	200.0	-	345.0	79	79	175	120	254.0	180.0	133	26
		200.0	145.0									
		200.0	168.0									

 **Mounting instruction:**

Compact type. Prebored or finish bore with keyway.  
Key connection not suitable for backlash-free torque transmission.

Coupling size	FD-C						FD-CL					
	M <sub>A1</sub>		S	DBSE <sup>1)</sup>	L <sub>F1</sub>	L <sub>F2</sub>	M <sub>A1</sub>		S	DBSE <sup>1)</sup>	L <sub>F1</sub>	L <sub>F2</sub>
	[ - ]	[ Nm ]	[ mm ]	[ mm ]	[ mm ]	[ mm ]	[ - ]	[ Nm ]	[ mm ]	[ mm ]	[ mm ]	[ mm ]
53	M5	7.0	6.9	43	72.5	53	-	-	-	-	-	-
72	M5	8.0	7.5	60	104.5	70	M5	9.0	7.6	60.2	104.7	70.2
				100	144.5	110				100.2	144.7	110.2
				140	184.5	150				140.2	184.7	150.2
89	M6	14.0	8.8	70	123.0	86	M6	15.0	9.0	70.4	123.4	86.4
				80	133.0	96				80.4	133.4	96.4
				100	153.0	116				100.4	153.4	116.4
				140	193.0	156				140.4	193.4	156.4
118	M8	31.0	10.4	100	165.0	120	M8	35.0	10.8	100.8	165.8	120.8
				140	205.0	160				140.8	205.8	160.8
				180	245.0	200				180.8	245.8	200.8
142	M10	62.0	12.0	100	171.0	122	M10	73.0	12.2	100.4	171.4	122.4
				140	211.0	162				140.4	211.4	162.4
				180	251.0	202				180.4	251.4	202.4
168	M12	110.0	13.0	100	187.0	124	M12	130.0	13.0	100.0	187.0	124.0
				140	227.0	164				140.0	227.0	164.0
				180	267.0	204				180.0	267.0	204.0
200	M14	180.0	15.0	140	244.0	168	M14	210.0	15.2	140.4	244.4	168.4
				180	284.0	208				180.4	284.4	208.4
238	M16	280.0	20.8	140	281.0	-	M16	320.0	22.0	142.4	283.4	-
				180	321.0	212				182.4	323.4	214.4
				250	391.0	282				252.4	393.4	284.4
295	M20	540.0	28.0	200	382.0	-	M20	620.0	28.2	200.4	382.4	-
				250	432.0	294				250.4	432.4	294.4
345	M24	950.0	32.2	224	450.0	-	M24	1000.0	32.4	224.4	450.4	-
				250	476.0	302				250.4	476.4	302.4
				300	526.0	352				300.4	526.4	352.4

 1) DBSE available up to 3 000 mm upon request

# FLEXDUR

Type N0 + S0

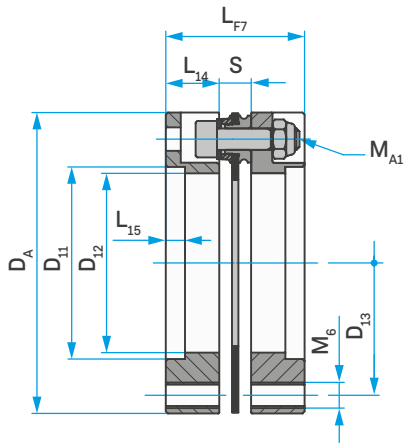

FD-C N0: Flange version

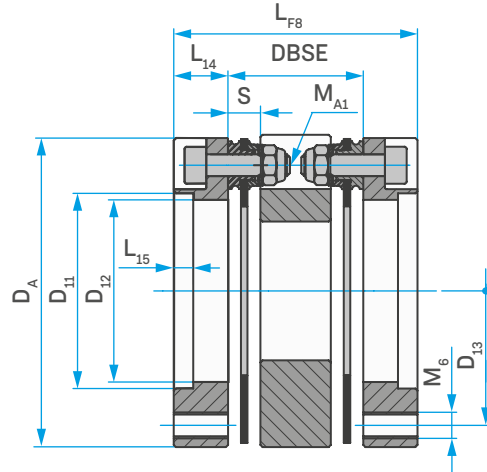

FD-C S0 DBSE<sub>min</sub>: flange version, short type



## Coupling details

Coupling size	L <sub>1</sub> [mm]	D <sub>A</sub> [mm]	D <sub>1</sub> [mm]	D <sub>3</sub> [mm]	L <sub>2</sub> [mm]	M <sub>1</sub> [mm]	D <sub>3</sub> [mm]
72	12.5	70.5	45	42	4.5	6xM8	62
89	17.0	88.0	50	48	4.5	6xM8	75
118	22.0	116.5	75	72	5.0	6xM10	103
142	27.0	140.5	92	89	5.0	6xM12	116
168	31.0	166.5	105	100	5.0	6xM14	140
200	34.0	198.5	120	115	7.0	6xM16	175
238	41.0	238.0	140	135	7.0	6xM20	210
295	52.0	306.0	160	155	7.0	8xM24	240
345	64.0	360.0	180	175	7.0	8xM30	275

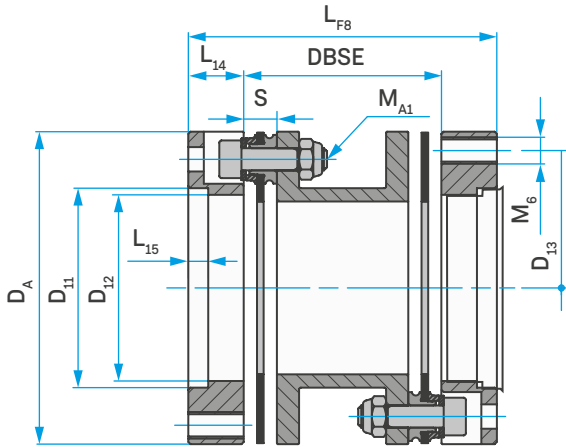

FD-C S0: Flange version

**Mounting instruction:**

Flange coupling. For disc pack disassembly, axial displacement of the flanges required.

**Drop out** with appropriate hubs possible. The complete coupling can be radially dismantled without any displacement of the components, and without releasing the screws of the disc pack.

Coupling size	FD-C						FD-CL					
	M <sub>A1</sub>		S	DBSE <sup>1)</sup>	L <sub>F1</sub>	L <sub>F2</sub>	M <sub>A1</sub>		S	DBSE <sup>1)</sup>	L <sub>F1</sub>	L <sub>F2</sub>
	[-]	[Nm]	[mm]	[mm]	[mm]	[mm]	[-]	[Nm]	[mm]	[mm]	[mm]	[mm]
72	M5	8.0	7.5	31.2	32.5	56.2	M5	9.0	7.6	31.4	32.6	56.4
				60.0		85.0				60.2		85.2
				100.0		125.0				100.2		125.2
				140.0		165.0				140.2		165.2
89	M6	14.0	8.8	37.6	42.8	71.6	M6	15.0	9.0	38.0	43.0	72.0
				70.0		104.0				70.4		104.4
				80.0		114.0				80.4		114.4
				100.0		134.0				100.4		134.4
118	M8	31.0	10.4	46.3	54.4	90.3	M8	35.0	10.8	47.1	54.8	91.1
				100.0		144.0				100.8		144.8
				140.0		184.0				140.8		184.8
				180.0		224.0				180.8		224.8
142	M10	62.0	12.0	55.0	66.0	109.0	M10	73.0	12.2	55.4	66.2	109.4
				100.0		154.0				100.4		154.4
				140.0		194.0				140.4		194.4
				180.0		234.0				180.4		234.4
168	M12	110.0	13.0	62.6	75.0	124.6	M12	130.0	13.0	62.6	75.0	124.6
				100.0		162.0				100.0		162.0
				140.0		202.0				140.0		202.0
				180.0		242.0				180.0		242.0
200	M14	180.0	15.0	140.0	83.0	208.0	M14	210.0	15.2	140.4	83.2	208.4
				180.0		248.0				180.4		248.4
238	M16	280.0	20.8	140.0	102.8	222.0	M16	320.0	22.0	142.4	104.0	224.4
				180.0		262.0				182.4		264.4
				250.0		332.0				252.4		334.4
295	M20	540.0	28.0	200.0	132.0	304.0	M20	620.0	28.2	200.4	132.2	304.4
				250.0		354.0				250.4		354.4
345	M24	950.0	32.2	224.0	160.2	352.0	M24	1000.0	32.4	224.4	160.4	352.4
				250.0		378.0				250.4		378.4
				300.0		428.0				300.4		428.4

<sup>1)</sup> DBSE available up to 3 000 mm upon request



# FLEXDUR

## Type NX + SX

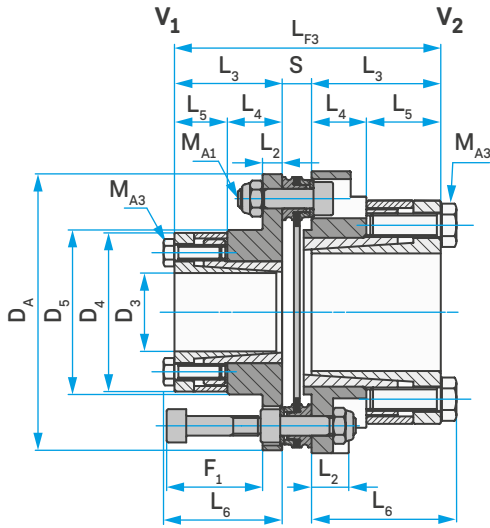

FD-C NX: with internal locking device

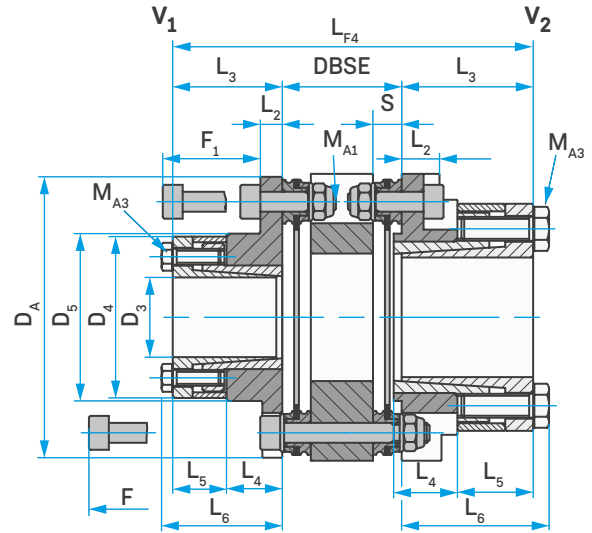

FD-C SX DBSE<sub>min</sub>: with internal locking device, short type

### Coupling details

Coupling size	Type	D <sub>A</sub> [mm]	L <sub>2</sub> [mm]	F [mm]	F <sub>1</sub> [mm]	L <sub>1</sub> [mm]	L <sub>3</sub> [mm]	L <sub>4</sub> [mm]	L <sub>5</sub> [mm]	D <sub>2</sub> [mm]	D <sub>3</sub> [mm]	M <sub>A2</sub> [-]	M <sub>A2</sub> [Nm]
53 + 145	V2	53.0	9.5	-	-	25.5	14.0	13.5	28.5	40.5	42	M4	5
72 + 145	V1	70.5	5.0	43	25	27.5	14.0	13.5	30.5	40.5	42	M4	5
72 + 330	V2	70.5	10.0	-	-	33.0	14.0	19.0	37.0	57.0	58	M6	17
89 + 500	V1	88.0	8.0	53	32	44.5	27.0	19.0	48.5	57.0	60	M6	17
89 + 920	V2	88.0	15.0	-	-	44.5	25.5	19.0	48.5	70.5	72	M6	17
118 + 1140	V1	116.5	10.0	67	40	35.0	16.5	18.5	39.0	74.0	80	M6	17
118 + 1370	V2	116.5	19.0	-	-	44.0	27.0	19.0	50.0	89.5	92	M6	17
142 + 920	V1	140.5	11.0	82	47	45.5	26.5	19.0	50.0	70.5	72	M6	17
142 + 2820	V1	140.5	11.0	82	47	59.5	36.5	23.0	65.0	96.5	98	M8	41
168 + 2820	V1	166.5	12.0	94	55	59.5	36.5	23.0	65.0	96.5	98	M8	41
200 + 2820	V1	198.5	14.0	-	64	59.5	36.5	23.0	65.0	96.5	98	M8	41

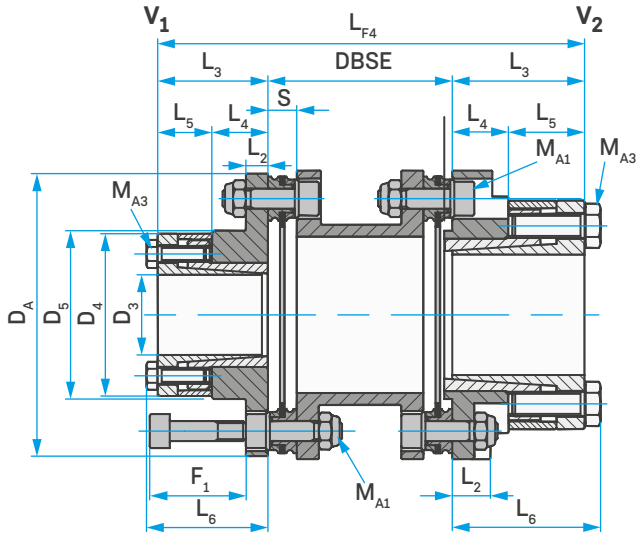

FD-C SX: with internal locking device

**Mounting instruction:**  
 Hub with internal locking device.  
 Backlash-free torque transmission.  
**V<sub>1</sub>**: Disc pack radial dismounting without hub displacement.  
**V<sub>2</sub>**: Radial disassembly of the disc pack after loosening and axial shifting of the clamping device possible.

Coupling size	FD-C						FD-CL					
	M <sub>A1</sub>		S	DBSE	L <sub>F1</sub>	L <sub>F2</sub>	M <sub>A1</sub>		S	DBSE	L <sub>F1</sub>	L <sub>F2</sub>
	[-]	[Nm]	[mm]	[mm]	[mm]	[mm]	[-]	[Nm]	[mm]	[mm]	[mm]	[mm]
53 + 145	M5	7.0	6.9	30.0	57.9	81.0	-	-	-	-	-	-
				43.0		94.0						
72 + 145	M5	8.0	7.5	31.2	62.5	86.2	M5	9.0	7.6	31.4	62.6	86.4
				60.0		115.0				60.2		115.2
				100.0		155.0				100.2		155.2
				140.0		195.0				140.2		195.2
				140.0		195.0				140.2		195.2
72 + 330	M5	8.0	7.5	31.2	73.5	97.2	M5	9.0	7.6	31.4	73.6	97.4
				60.0		126.0				60.2		126.2
				100.0		166.0				100.2		166.2
				140.0		206.0				140.2		206.2
				140.0		206.0				140.2		206.2
89 + 500	M6	14.0	8.8	37.6	97.8	126.6	M6	15.0	9.0	38.0	98.0	127.0
				70.0		159.0				70.4		159.4
				80.0		169.0				80.4		169.4
				100.0		189.0				100.4		189.4
				140.0		229.0				140.4		229.4
89 + 920	M6	14.0	8.8	37.6	97.8	126.6	M6	15.0	9.0	38.0	98.0	127.0
				70.0		159.0				70.4		159.4
				80.0		169.0				80.4		169.4
				100.0		189.0				100.4		189.4
				140.0		229.0				140.4		229.4
118 + 1140	M8	31.0	10.4	46.3	80.4	116.3	M8	35.0	10.8	47.1	80.8	117.1
				100.0		170.0				100.8		170.4
				140.0		210.0				140.8		210.4
				180.0		250.0				180.8		250.4
				180.0		250.0				180.8		250.4
118 + 1370	M8	31.0	10.4	46.3	98.4	134.3	M8	35.0	10.8	47.1	98.8	135.1
				100.0		188.0				100.8		188.4
				140.0		228.0				140.8		228.4
				180.0		268.0				180.8		268.4
				180.0		268.0				180.8		268.4
142 + 920	M10	62.0	12.0	55.0	103.0	146.0	M10	73.0	12.2	55.4	103.2	146.4
				100.0		191.0				100.4		191.4
				140.0		231.0				140.4		231.4
				180.0		271.0				180.4		271.4
				180.0		271.0				180.4		271.4
142 + 2820	M10	62.0	12.0	55.0	131.0	174.0	M10	73.0	12.2	55.4	131.2	174.4
				100.0		219.0				100.4		219.4
				140.0		259.0				140.4		259.4
				180.0		299.0				180.4		299.4
				180.0		299.0				180.4		299.4
168 + 2820	M12	110.0	13.0	62.6	132.0	181.6	M12	130.0	-	-	-	-
				100.0		219.0						
				140.0		259.0						
				180.0		299.0						
				180.0		299.0						
200 + 2820	M14	180.0	15.0	140.0	134.0	259.0	M14	210.0	-	-	-	-
				180.0		299.0						

Type NX - SX Preferred bores [mm]/transmittable torque [Nm] of the clamping set for shaft tolerance h8

Size	D <sub>1</sub> [mm]	11	12	14	15	16	18	19	20	22	24	25	28	30	32	35	38	40	42	45	48	50	55	60	
145 [Nm]		50	55	90	95	115	130	140	145	-	-	-	-	-	-	-	-	-	-	-	-	-	-	-	
330 [Nm]		-	-	-	-	-	-	195	200	240	265	275	310	330	-	-	-	-	-	-	-	-	-	-	
500 [Nm]		-	-	-	-	-	-	310	330	360	400	410	460	500	-	-	-	-	-	-	-	-	-	-	
920 [Nm]		-	-	-	-	-	-	-	-	-	470	490	550	590	700	770	840	880	920	-	-	-	-	-	
1140 [Nm]		-	-	-	-	-	-	-	-	-	-	-	-	-	540	710	780	820	950	1020	1090	1140	-	-	
1370 [Nm]		-	-	-	-	-	-	-	-	-	-	-	-	-	-	-	-	-	-	-	-	-	1250	1370	
2820 [Nm]		-	-	-	-	-	-	-	-	-	-	-	-	1240	1330	1420	1550	1780	1880	1970	2110	2250	2350	2590	2820

# FLEXDUR

## Type NZ + SZ

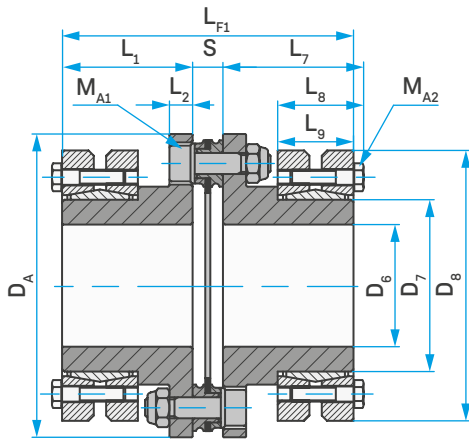

FD-C NZ: with outside clamping set

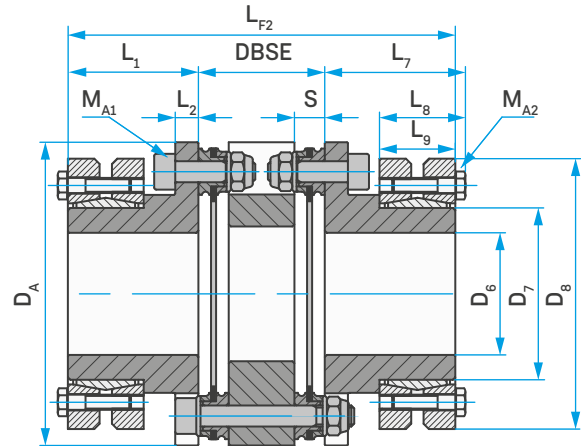

FD-C SZ DBSE<sub>min</sub>: with outside clamping set, short type



### Coupling details

Coupling size	D <sub>2</sub>	L <sub>1</sub>	L <sub>3</sub>	D <sub>A</sub>	D <sub>1</sub> <sup>2)</sup>	L <sub>2</sub>	D <sub>3</sub>	L <sub>4</sub>	L <sub>5</sub>	M <sub>A2</sub>		TL Limited torque
	[mm]	[mm]	[mm]		[mm]		[mm]	[mm]	[mm]	[mm]	[mm]	
89	30	45.0	48.5	88.0	24-25-26	8	60	24.5	21	M5	6	310-340-380
	36		49.0		28-30-31		72	27.0	23	M6	12	460-590-630
	44		49.0		32-35-36		80	29.0	25	M6	12	630-780-860
	50		49.0		38-40-42		90	31.0	27	M6	12	940-1100-1300
118	50	55.0	59.0	116.5	38-40-42	10	90	31.0	27	M6	12	940-1100-1300
	55		59.0		42-45-48		100	34.0	30	M6	12	1200-1500-1900
	75		60.5		50-55-60-65		138	37.5	32	M8	30	2000-2500-3200-3900
142	68	60.0	64.0	140.5	50-55-60	11	115	34.0	30	M6	12	2000-2500-3100
	90	63.5	69.0		65-70-75		155	44.5	39	M8	30	4700-6000-7200
168	68	75.0	79.0	166.5	50-55-60	12	110	34.0	30	M6	12	2000-2500-3100
	90	75.0	80.5		65-70-75		155	44.5	39	M8	30	4700-6000-7200
	115	80.5	87.0		80-85-90		188	56.5	50	M10	59	8500-10000-12000
200	68	90.0	94.0	198.5	50-55-60	14	110	34.0	30	M6	12	2000-2500-3100
	90		95.5		65-70-75		155	44.5	39	M8	30	4700-6000-7200
	115		96.5		80-85-90		188	56.5	50	M10	59	8500-10000-12000
	130		97.0		90-95-100-110		215	59.0	52	M10	59	13700-15800-18200-23500
	100		125.0		130.5		70-75-80	170	49.5	44	M8	30
238	130	125.0	132.0	238.0	90-95-100-110	16	215	59.0	52	M10	59	13700-15800-18200-23500
	155	125.0	132.5		105-110-115-120		265	71.5	64	M12	100	20000-23000-26000-29500
	165	129.0	139.0		115-120-125-135		290	81.0	71	M16	250	36000-39000-44000-51200
	130	160.0	167.0		90-95-100-110		215	59.0	52	M10	59	13700-15800-18200-23500
295	160	160.0	167.5	295.0	110-115-120-125	22	265	71.5	64	M12	100	22500-25500-28600-33000
	175		170.0		125-130-135-140		300	81.0	71	M16	250	40000-44000-49000-52500
	185		170.0		130-140-145-150		330	96.0	86	M16	250	50000-55000-60000-65000
	195		170.0		140-150-155-165		350	96.0	86	M16	250	66000-76000-82000-96000
	170		210.0		210.0		120-125-130-135	290	81.0	71	M16	250
345	195	200.0	210.0	345.0	140-150-155-165	26	350	96.0	86	M16	250	66000-76000-82000-96000
	220		210.0		160-165-170-180		370	114.0	104	M16	250	95000-102000-110000-128000
	250		212.5		180-190-200-210		405	120.5	108	M16	250	160000-180000-200000-212000
	195		220.0		140-150-155-165		350	96.0	86	M16	250	66000-76000-82000-96000
	220		210.0		160-165-170-180		370	114.0	104	M16	250	95000-102000-110000-128000
420	260	210.0	222.5	420.0	180-190-200-220	32	430	132.5	120	M20	490	165000-185000-204000-214000
	220		250.0		160-165-170-180		370	114.0	104	M16	250	95000-102000-110000-128000
	260		252.5		180-190-200-220		430	132.5	120	M16	250	165000-185000-204000-214000
	300		260.0		230-240-250-260		485	142.0	122	M20	490	274000-296000-316000-364000

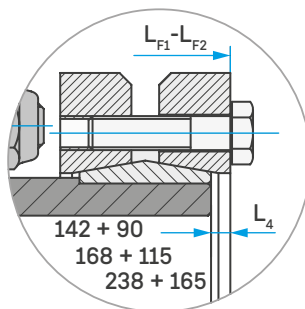
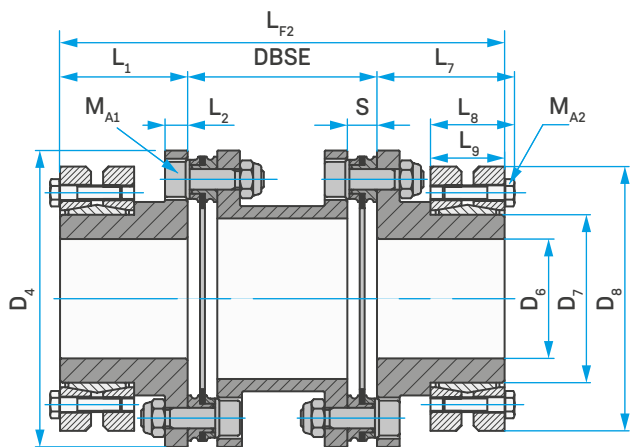

### Mounting instruction:

Hub with outside clamping set. Backlash-free torque transmission. Radial disassembly of the disc pack after loosening and axial shifting of the clamping device possible.

FD-C SZ: with outside clamping set

Coupling size	FD-C						FD-CL								
	M <sub>A1</sub> [-]	M <sub>A1</sub> [Nm]	S [mm]	DBSE <sup>1)</sup> [mm]	L <sub>F1</sub> [mm]	L <sub>F2</sub> [mm]	M <sub>A1</sub> [-]	M <sub>A1</sub> [Nm]	S [mm]	DBSE <sup>1)</sup> [mm]	L <sub>F1</sub> [mm]	L <sub>F2</sub> [mm]			
89	M6	14.0	8.8	37.6	98.8	127.6	M6	15.0	9.0	-	99.0	128.0			
				70.0		160.0						160.4			
				80.0		170.0						170.4			
				100.0		190.0						190.4			
				140.0		230.0						230.4			
118	M8	31.0	10.4	46.3	100.4	156.3	M8	35.0	10.8	-	100.8	157.1			
				100.0		210.0						210.4			
				140.0		250.0						250.4			
				180.0		290.0						290.4			
				180.0		290.0						290.4			
142	M10	62.0	12.0	55.0	132.0	175.0	M10	73.0	12.2	-	132.2	175.4			
				100.0		220.0						220.4			
				140.0		260.0						260.4			
				180.0		300.0						300.4			
				180.0		300.0						300.4			
				55.0	139.0	182.0 <sup>3)</sup>						-	139.2	182.4	
				100.0		227.0 <sup>3)</sup>								227.4 <sup>3)</sup>	
				140.0		267.0 <sup>3)</sup>								267.4 <sup>3)</sup>	
				180.0		307.0 <sup>3)</sup>								307.4 <sup>3)</sup>	
				180.0		307.0 <sup>3)</sup>								307.4 <sup>3)</sup>	
168	M12	110.0	13.0	62.6	163.0	216.6	M12	130.0	13.0	-	163.0	216.6			
				100.0		250.0						250.0			
				140.0		290.0						290.0			
				180.0		320.0						320.0			
				100.0		174.0						261.0 <sup>4)</sup>	-	174.0	261.0 <sup>4)</sup>
				140.0								301.0 <sup>4)</sup>			301.0 <sup>4)</sup>
				180.0								341.0 <sup>4)</sup>			341.0 <sup>4)</sup>
200	M14	180.0	15.0	140.0	195.0	320.0	M14	210.0	15.2	-	195.2	320.4			
				180.0		360.0						360.4			
238	M16	280.0	20.8	140.0	270.8	390.0	M16	320.0	22.0	-	272.0	392.4			
				180.0		430.0						432.4			
				250.0		500.0						502.4			
				140.0		278.8						398.0 <sup>5)</sup>	-	278.0	400.4 <sup>5)</sup>
				180.0								438.0 <sup>5)</sup>			440.4 <sup>5)</sup>
				250.0	508.0 <sup>5)</sup>	510.4 <sup>5)</sup>									
				295	M20	540.0						28.0	200.0	348	520.0
250.0	570.0	570.4													
345	M24	950.0	32.2	224.0	432.2	624.0	M24	1000.0	32.4	-	432.4	624.4			
				250.0		650.0						650.4			
				300.0		700.0						700.4			
420	M10	60.0	34.0	280.0	454.0	700.0	-	-	-	-	-	-			
510	M12	105.0	46.8	350.0	526.8	830.0	-	-	-	-	-	-			

1) DBSE available up to 3 000 mm upon request 2) Fitting tolerances for shaft and hub: Ø 24 - Ø 30 = H6-j6 / Ø 30 - Ø 50 = H6-h6 / Ø 50 - Ø 80 = H6-g6 / Ø 80 - Ø 260 = H7-g6 3) L<sub>G</sub>= 3.5 - 4) L<sub>G</sub>=5.5 - 5) L<sub>G</sub>=4

# FLEXDUR

## Type F

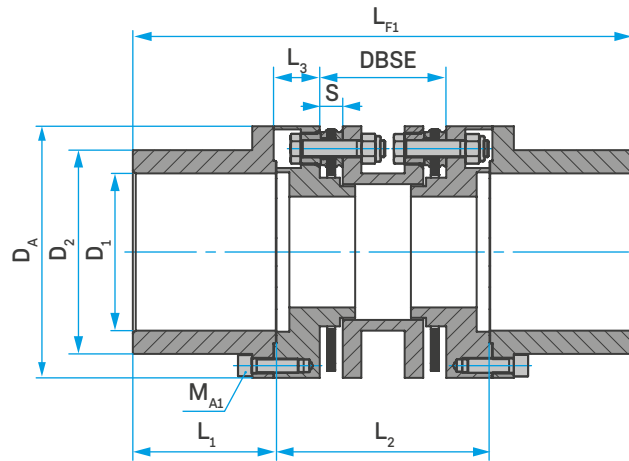

FD-C F: API 610 + 671



### Coupling details

Coupling size	$L_1$ [mm]	$D_A$ [mm]	$D_{1min}$ pre-drilled [mm]	$D_{1max}$ [mm]	$D_2$ [mm]	$L_3$ [mm]
89	50	94	14	50	69	20
118	70	121	14	70	91	23
142	80	148	19	80	112	26
168	100	176	24	105	135	32.5
200	120	202	29	120	160	37
238	140	250	39	140	192	43.5
295	180	302	59	180	240	50.5
345	200	352	79	220	285	64.5



 **Mounting instruction:**

Special types according to API 610/671 specification.  
The complete coupling unit can be radially dismantled without any displacement of the shafts, and without releasing the screws of the disc packs. Catch device to secure the spacer coupling in case of disc breakage.

Coupling size	FD-C						FD-CL					
	M <sub>A1</sub>		S [mm]	DBSE <sup>1)</sup> [mm]	L <sub>2</sub> <sup>1)</sup> [mm]	L <sub>F1</sub> [mm]	M <sub>A1</sub>		S [mm]	DBSE <sup>1)</sup> [mm]	L <sub>2</sub> <sup>1)</sup> [mm]	L <sub>F1</sub> [mm]
	[-]	[Nm]					[-]	[mm]				
89	M6	17	8.8	50	88	188	M6	17	9.0	50.4	88.4	188.4
				62	100	200				62.4	100.4	200.4
				102	140	240				102.4	140.4	240.4
118	M8	41	10.4	61	105	245	M8	41	10.8	61.8	105.8	245.8
				96	140	280				96.8	140.8	280.8
				136	180	320				136.8	180.8	320.8
142	M8	41	12	63	112	272	M8	41	12.2	63.4	112.4	272.4
				91	140	300				91.4	140.4	300.4
				131	180	340				131.4	180.4	340.4
168	M10	83	13	74	135	335	M10	83	13.0	74.0	135.0	335.0
				119	180	380				119.0	180.0	380.0
				189	250	450				189.0	250.0	450.0
200	M12	145	15	90	160	400	M12	145	15.2	90.4	160.4	400.4
				110	180	420				110.4	180.4	420.4
				180	250	490				180.4	250.4	490.4
238	M16	355	20.8	105.4	188	468	M16	355	22.0	107.8	190.4	470.4
				167.4	250	530				169.8	252.4	532.4
				217.4	300	580				219.4	302.4	582.0
295	M16	355	28	138	235	595	M16	355	28.2	138.4	235.4	595.4
				153	250	610				153.4	250.4	610.4
				203	300	660				203.4	300.4	660.4
345	M20	690	32.2	155	278	678	M20	690	32.4	155.4	278.4	678.4
				177	300	700				177.4	300.4	700.4
				227	350	750				227.4	350.4	750.4

 1) DBSE available up to 3000 mm upon request

# FLEXDUR

Type NY + SY

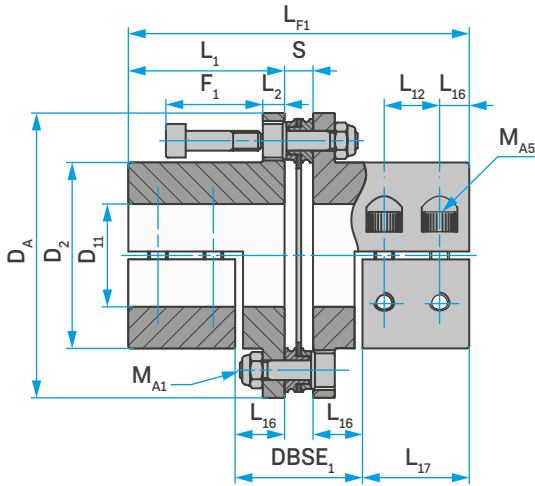

FD-C NY: with clamping hub, split

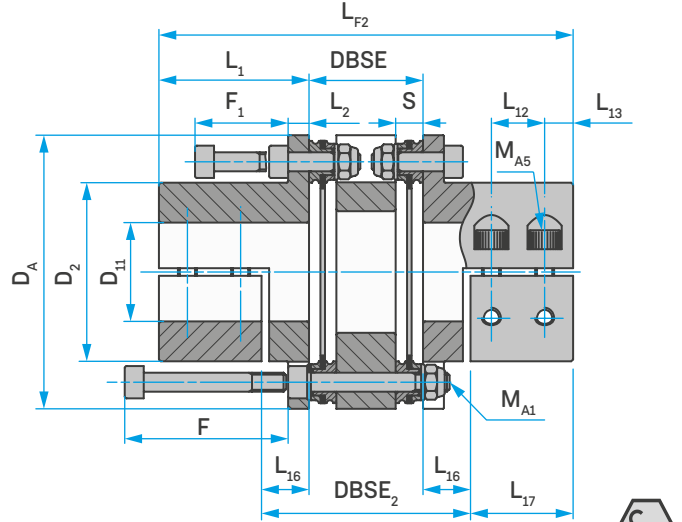

FD-C SY DBSE<sub>min</sub>: with clamping hub, split, short type



## Coupling details

Coupling size	L <sub>1</sub>	D <sub>A</sub>	D <sub>2</sub>	F	F <sub>1</sub>	L <sub>2</sub>	M <sub>A2</sub>		L <sub>4</sub>	L <sub>5</sub>	L <sub>3</sub>	L <sub>6</sub>
	[mm]	[mm]	[mm]	[mm]	[mm]	[mm]	[-]	[Nm]	[mm]	[mm]	[mm]	[mm]
72	39.5	70.5	47.0	43.0	24.0	5.0	M6	17.0	7.5	12.5	13.0	27.0
							M5	9.7				
89	45.0	88.0	62.5	53.0	32.0	8.0	M8	41.0	8.0	17.5	14.0	27.5
							M6	17.0				
118	55.0	116.5	82.0	67.0	40.0	10.0	M10	83.0	10.0	21.0	17.0	34.0
							M8	41.0				
142	60.0	140.5	98.0	82.0	47.0	11.0	M10	83.0	10.0	25.0	18.5	35.0
168	75.0	166.5	118.0	94.0	55.0	12.0	M12	145.0	13.0	30.0	23.0	45.0

Type NY - SY preferred bores [mm]/transmittable torque [Nm] of the clamping set for shaft tolerance h7 without parallel key

D <sub>1</sub> max	Size																						M <sub>A2</sub>				
	15	16	18	19	20	22	24	25	28	30	32	35	38	40	42	45	48	50	55	60	65	70	75	80	[-]	[Nm]	
72	130	140	155	165	175	190	210	220	-	-	-	-	-	-	-	-	-	-	-	-	-	-	-	-	M6	17.0	
	-	-	-	-	-	-	-	170	185	-	-	-	-	-	-	-	-	-	-	-	-	-	-	-	M5	9.7	
89	-	-	-	-	320	350	385	400	450	480	515	560	-	-	-	-	-	-	-	-	-	-	-	-	M8	41.0	
	-	-	-	-	-	-	-	-	-	-	-	335	350	-	-	-	-	-	-	-	-	-	-	-	M6	17.0	
118	-	-	-	-	-	-	-	-	-	780	835	910	990	1040	1095	1175	-	-	-	-	-	-	-	-	M10	83.0	
	-	-	-	-	-	-	-	-	-	-	-	-	-	-	-	770	805	885	-	-	-	-	-	-	M8	41.0	
142	-	-	-	-	-	-	-	-	-	780	835	910	990	1040	1095	1175	1250	1305	1435	1565	1700	-	-	-	M10	83.0	
168	-	-	-	-	-	-	-	-	-	-	-	-	1350	1470	1545	1625	1740	1855	1935	2125	2320	2515	2700	2900	3095	M12	145

M<sub>A2</sub> [Nm] = clamping screw tightening torque

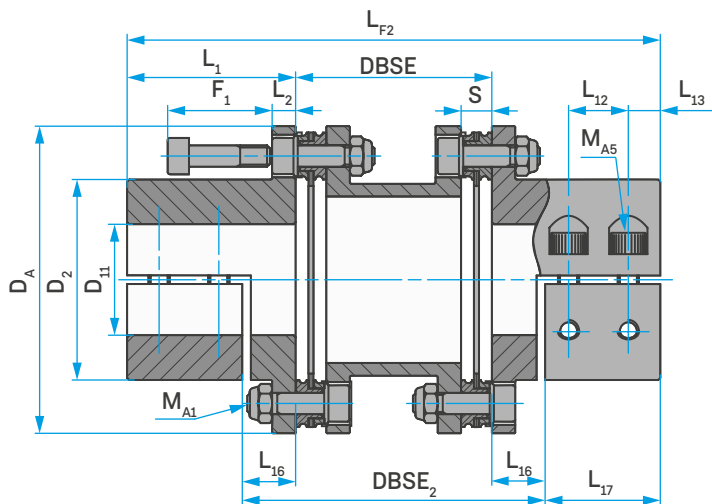

FD-C SY: with clamping hub, split

Standard

with keyway

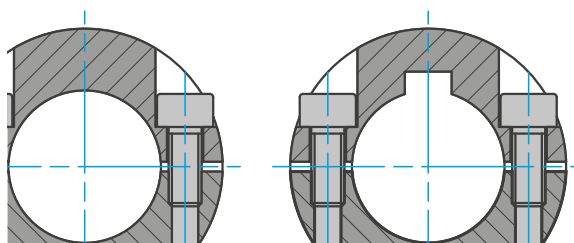

**Mounting instruction:**

Clamping hub, split. Bore with keyway available. Backlash-free torque transmission. Disc pack radial dismounting without hub displacement. The complete coupling can be radially dismounted without any displacement of the shafts, and without releasing the screws of the disc pack.

Coupling size	FD-C								FD-CL							
	M <sub>A1</sub>		S	DBSE <sup>1)</sup>	DBSE <sub>1</sub>	L <sub>F1</sub>	DBSE <sub>2</sub>	L <sub>F2</sub>	M <sub>A1</sub>		S	DBSE <sup>1)</sup>	DBSE <sub>1</sub>	L <sub>F1</sub>	DBSE <sub>2</sub>	L <sub>F2</sub>
	[-]	[Nm]	[mm]	[mm]	[mm]	[mm]	[mm]	[mm]	[-]	[Nm]	[mm]	[mm]	[mm]	[mm]	[mm]	[mm]
72	M5	8	7.5	31.2	32.5	86.5	56.2	110.2	M5	9	7.6	31.4	32.6	86.6	56.4	110.4
				60.0			85.0	139.0				60.2			85.2	139.2
				100.0			125.0	179.0				100.2			125.2	179.2
				140.0			165.0	219.0				140.2			165.2	219.2
89	M6	14	8.8	37.6	43.8	98.8	72.6	127.6	M6	15	9.0	38.0	44.0	99.0	73.0	128.0
				70.0			105.0	160.0				70.4			105.4	160.4
				80.0			115.0	170.0				80.4			115.4	170.4
				100.0			135.0	190.0				100.4			135.4	190.4
				140.0			175.0	230.0				140.4			175.4	230.4
118	M8	31	10.4	46.3	52.4	120.4	88.3	156.3	M8	35	10.8	47.1	52.8	120.8	89.1	157.1
				100.0			142.0	210.0				100.8			142.8	210.8
				140.0			182.0	250.0				140.8			182.8	250.8
				180.0			222.0	290.0				180.8			222.8	290.8
				55.0			105.0	175.0				55.4			105.4	175.4
142	M10	62	12.0	100.0	62.0	132.0	150.0	220.0	M10	73	12.2	100.4	62.2	132.2	150.4	220.4
				140.0			190.0	260.0				140.4			190.4	260.4
				180.0			230.0	300.0				180.4			230.4	300.4
				62.6			122.6	212.6				62.6			-	212.6
				100.0			160.0	250.0				100.0			160.0	250.0
168	M12	110	13.0	140.0	73.0	163.0	200.0	290.0	M12	130	13.0	140.0	73.0	163.0	200.0	290.0
				180.0			240.0	330.0				180.0			240.0	330.0

**i** 1) DBSE available up to 3000 mm upon request

# FLEXDUR

## Type NK + SK

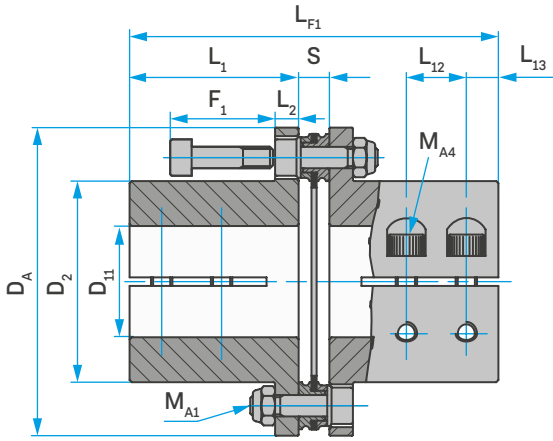

FD-C NK: with clamping hub, slotted

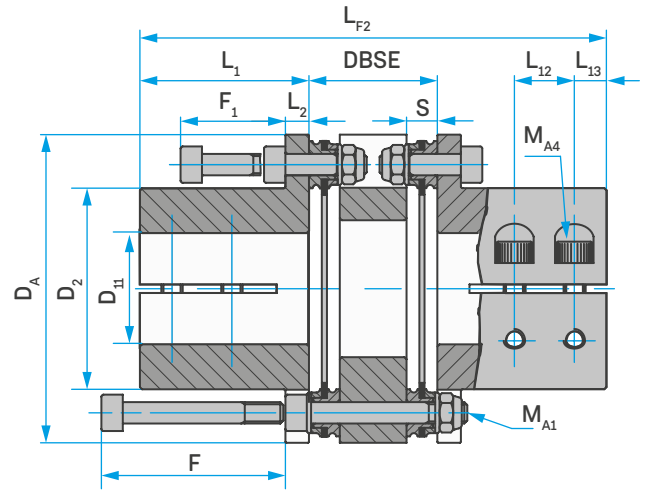

FD-C SK DBSE<sub>min</sub>: with clamping hub, slotted, short type

### Coupling details

Coupling size	L <sub>1</sub> [mm]	D <sub>A</sub> [mm]	D <sub>2</sub> [mm]	F [mm]	F <sub>1</sub> [mm]	L <sub>2</sub> [mm]	M <sub>A2</sub>		L <sub>3</sub> [mm]	L <sub>4</sub> [mm]
							[-]	[Nm]		
40	17.0	40.0	26.0	25.0	15.0	4.0	M4	5.2	-	4.5
							M3	2.6		
53	24.5	53.0	32.5	43.0	24.0	5.0	M4	5.2	9.0	5.0
72	39.5	70.5	47.0	43.0	24.0	5.0	M6	17.0	13.0	7.5
89	45.0	88.0	62.5	53.0	32.0	8.0	M8	41.0	16.0	9.0
118	55.0	116.5	82.0	67.0	40.0	10.0	M10	83.0	19.5	10.5
142	60.0	140.5	98.0	82.0	47.0	11.0	M10	83.0	20.0	11.5

Type NK - SK preferred bores [mm]/transmittable torque [Nm] of the clamping set for shaft tolerance h7 without parallel key

Size	D <sub>1</sub> max	D <sub>1</sub> [mm]																				M <sub>A2</sub>						
		8	10	11	12	14	15	16	18	19	20	22	24	25	28	30	32	35	38	40	42	45	48	50	55	60	[-]	[Nm]
40	9	12	12	-	-	-	-	-	-	-	-	-	-	-	-	-	-	-	-	-	-	-	-	-	-	-	M4	5.2
		-	-	-	12	15	-	-	-	-	-	-	-	-	-	-	-	-	-	-	-	-	-	-	-	-	M3	2.6
53	-	-	-	50	55	60	70	82	95	100	-	-	-	-	-	-	-	-	-	-	-	-	-	-	-	M4	5.2	
72	-	-	-	-	-	65	75	90	100	115	140	170	180	-	-	-	-	-	-	-	-	-	-	-	-	M6	17.0	
89	-	-	-	-	-	-	-	-	-	120	150	180	210	250	300	350	360	-	-	-	-	-	-	-	-	M8	41.0	
118	-	-	-	-	-	-	-	-	-	-	-	-	-	-	360	420	490	550	650	720	790	-	-	-	-	M10	83.0	
142	-	-	-	-	-	-	-	-	-	-	-	-	-	-	340	380	420	470	500	600	650	750	900	1200	1450	M10	83.0	

M<sub>A2</sub> [Nm] = clamping screw tightening torque

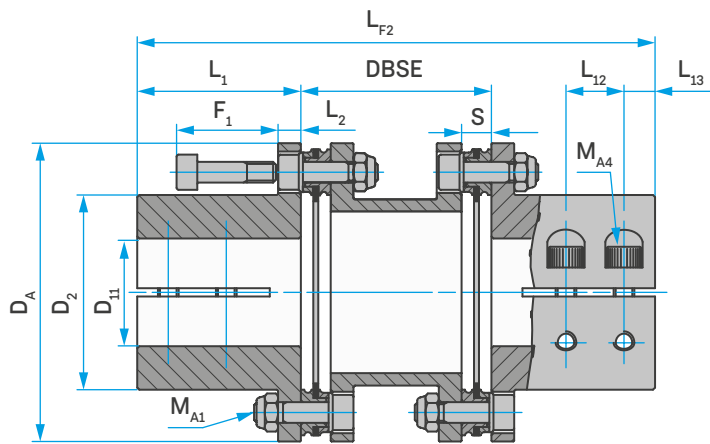

FD-C SK: with clamping hub, slotted

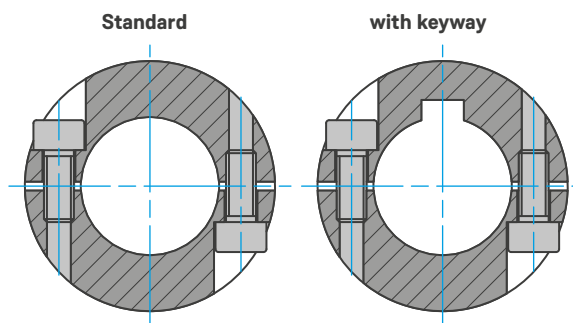

**Mounting instruction:**

- Clamping hub, slotted. Bore with keyway available.
- Backlash-free torque transmission.
- Disc pack radial dismounting without hub displacement.

Coupling size	FD-C						FD-CL					
	M <sub>A1</sub>		S	DBSE <sup>1)</sup>	L <sub>F1</sub>	L <sub>F2</sub>	M <sub>A1</sub>		S	DBSE <sup>1)</sup>	L <sub>F1</sub>	L <sub>F2</sub>
	[-]	[Nm]	[mm]	[mm]	[mm]	[mm]	[-]	[Nm]	[mm]	[mm]	[mm]	[mm]
40	M3	1.5	2.9	16.0	36.9	50.0	-	-	-	-	-	-
				26.0		60.0						
53	M5	7.0	6.9	30.0	55.9	79.0	-	-	-	-	-	-
				43.0		92.0						
72	M5	8.0	7.5	31.2	86.5	110.2	M5	9	7.6	31.4	86.6	110.4
				60.0		139.0				60.2		139.2
				100.0		179.0				100.2		179.2
				140.0		219.0				140.2		219.2
89	M6	14.0	8.8	37.6	98.8	127.6	M6	15	9.0	38.0	99.0	128.0
				70.0		160.0				70.4		160.4
				80.0		170.0				80.4		170.4
				100.0		190.0				100.4		190.4
118	M8	31.0	10.4	46.3	120.4	156.3	M8	35	10.8	47.1	120.8	157.1
				100.0		210.0				100.8		210.8
				140.0		250.0				140.8		250.8
				180.0		290.0				180.8		290.8
142	M10	62.0	12.0	55.0	132.0	175.0	M10	73	12.2	55.4	132.2	175.4
				100.0		220.0				100.4		220.4
				140.0		260.0				140.4		260.4
				180.0		300.0				180.4		300.4

<sup>1)</sup> DBSE available up to 3 000 mm upon request

# FLEXDUR

## Type SP-CA + SP-CB

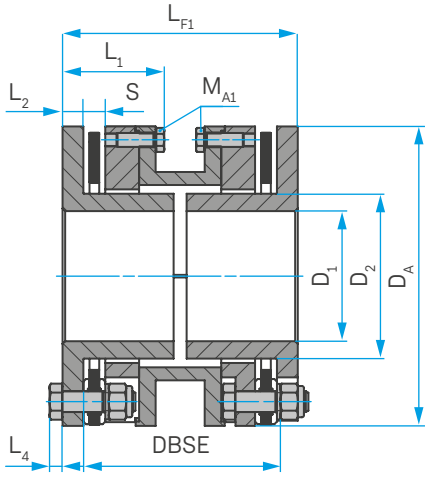

**FD-C SP-CA:** Compact, short type, split spacer

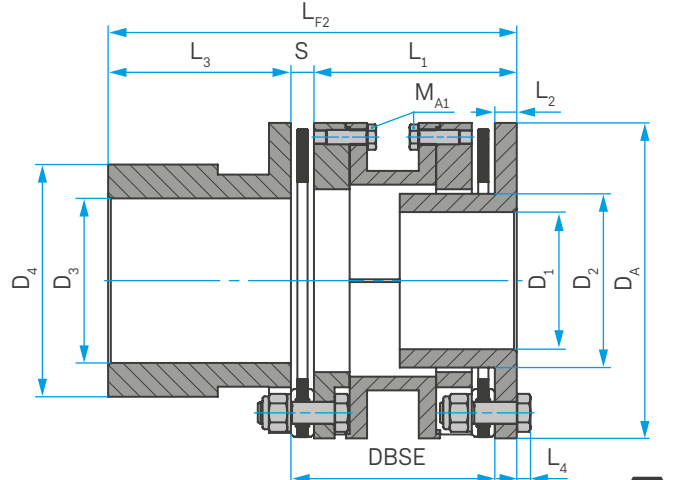

**FD-C SP-CB:** Compact, split spacer



### Coupling details

Coupling size	L <sub>1</sub> [mm]	L <sub>3</sub> [mm]	D <sub>A</sub> [mm]	D <sub>1max</sub> [mm]	D <sub>3max</sub> [mm]	D <sub>2</sub> [mm]	D <sub>4</sub> [mm]	L <sub>2</sub> [mm]	L <sub>4</sub> [mm]
89	45	45	88	35	45 <sup>1)</sup>	48	58	7	4
118	45	55	116.5	50	60	64	81	8	5.5
142	53	60	140.5	60	70	77	94	9	7
168	64	75	166.5	75 <sup>1)</sup>	90	93	115	11	8
200	71	90	198.5	90 <sup>1)</sup>	110 <sup>1)</sup>	114	136	12.5	9
238	82	125	238	100	120	135	169	14.5	10
295	112	160	295	130	150	170	205	19	13
345	128	200	345	150 <sup>1)</sup>	180	190	254	24	15

<sup>1)</sup> D<sub>1max</sub> - D<sub>3max</sub> with keyway according to DIN 6885/3

 **Mounting instruction:**

Compact type with split spacer.

Prebored or finish bore with keyway.

Special design enables maintenance of the coupling without moving the hubs and without disassembling the disc pack.

Coupling size	FD-C						FD-CL					
	M <sub>A1</sub>		S	DBSE	L <sub>F1</sub>	L <sub>F2</sub>	M <sub>A1</sub>		S	DBSE	L <sub>F1</sub>	L <sub>F2</sub>
	[-]	[Nm]	[mm]	[mm]	[mm]	[mm]	[-]	[Nm]	[mm]	[mm]	[mm]	[mm]
89	M5	8	6.8	80	102	136	M5	8	7	80.4	102.4	136.4
118	M6	14	9.4	79	106	147.5	M6	14	9.8	79.8	106.8	148.3
142	M8	35	9.6	93	125	169	M8	35	9.8	93.4	125.4	169.4
168	M8	35	11.6	112	150	206	M8	35	11.6	112	150	206
200	M10	69	12.0	124	167	235.5	M10	69	12.2	124.4	167.4	235.9
238	M12	120	15.8	144	193	293.5	M12	120	17	146.4	195.4	295.4
295	M14	190	24.0	199	263	391	M14	190	24.2	199.4	263.4	391.4
345	M16	295	25.2	223	301	462	M16	295	25.4	223.4	301.4	462.4



## FLEXDUR

SIMPLY **POWERFUL.** ————— □

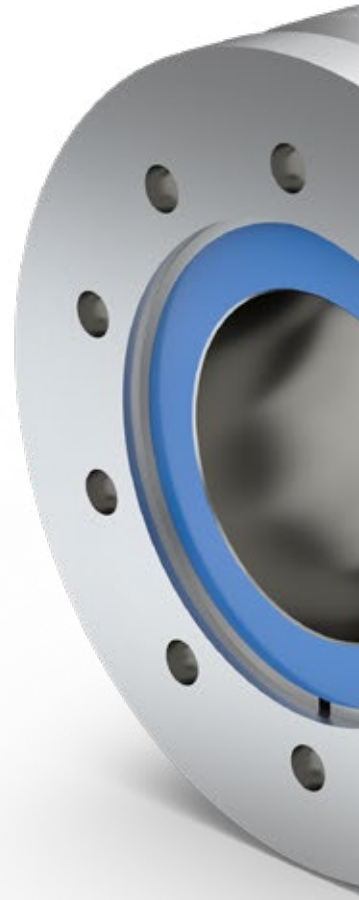

### Industrial solutions:

- ⚡ Power generation
- 🚛 Mobile applications
- 💡 Test benches
- 🔧 Pumps & Compressors
- ⚙️ Industry
- ⚓ Marine engineering

### Headquarters:

Dipl. - Ing. Herwarth Reich GmbH  
Vierhausstrasse 53 · 44807 Bochum, Germany  
☎ +49 234 959 16-0  
✉ [mail@reich-kupplungen.com](mailto:mail@reich-kupplungen.com)  
🌐 [www.reich-kupplungen.com](http://www.reich-kupplungen.com)

### Copyright ISO 16016 to be observed:

The reproduction, distribution and utilisation of this document as well as the communication of its contents to others without explicit authorisation is prohibited. Offenders will be held liable for the payment of damages. All rights reserved in the event of the grant of a patent, utility model or design. © REICH - Dipl.- Ing. Herwarth Reich GmbH

### January 2024 edition

The present FLEXDUR catalogue edition renders parts of the previous FLEXDUR catalogues obsolete. All dimensions are given in millimetres. We reserve the right to change dimensions and/or design without prior notice. Texts and illustrations, dimensional and performance data have been compiled with the utmost care. There is no guarantee, however, that the information is accurate; in particular, there is no guarantee that products will match the illustrations in terms of technology, colour, shape and configuration or that the products will correspond to the proportions of the illustrations. We also reserve the right to make changes due to printing errors or mistakes.